



Voxeo Corporation

2004 Overview





Voxeo Mission

Since 1999, Voxeo has focused on one goal -

Helping enterprises create and deploy
valuable, reliable, and comfortable
IVR and telephony applications.

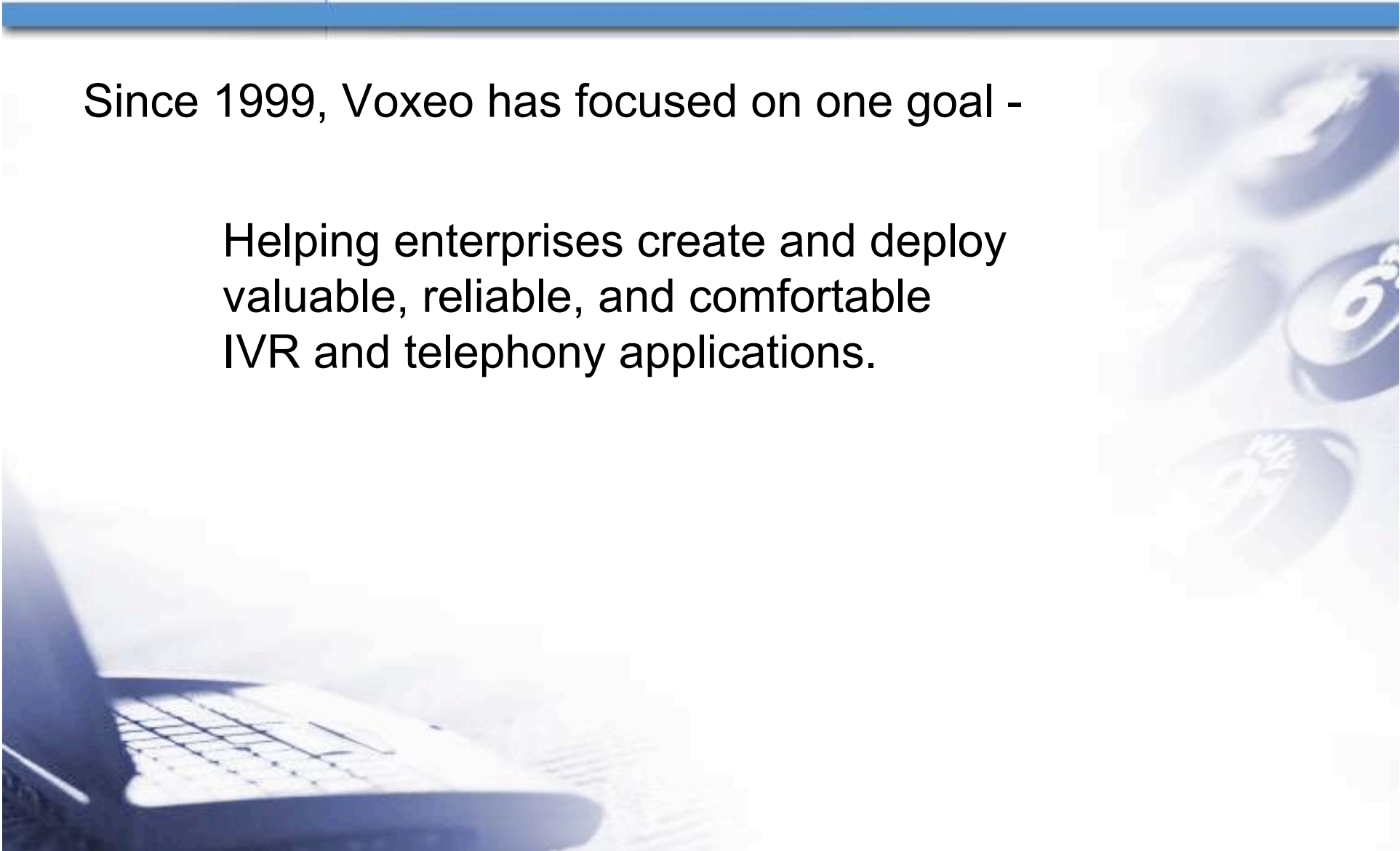



Products & Services

- **Voxeo VoiceCenter**
 - IVR Platforms & Hosting
- **Voxeo Evolution**
 - IVR Developer Solutions
- **Voxeo Extreme**
 - IVR Support & Pro services
- **Voxeo VoiceWorks**
 - IVR Applications





Business Overview

- Founded in 1999
- Over 200 customers
- Profitable since 2003
- Over 100% year-on-year growth since 2001
- Shipping VoiceXML since 2000, CCXML since 2002
- Over 350 million CCXML & VoiceXML calls completed



Business Differentiators

- **Profitability**
 - Voxeo is the first profitable VoiceXML/CCXML IVR hosting company.
- **Proven, standards-based platform and process**
 - Voxeo has delivered 100% standards-based IVR solutions since 1999.
- **Unwavering focus on customer service excellence**
 - Everyone from the CEO to tier-1 support puts customers first.
- **Versatility and Reliability**
 - Voxeo offers unmatched features - backed by a 100% uptime SLA.
- **Comprehensive solutions**
 - Voxeo brings enterprises packaged, best-of-breed technology & services.



Platform Differentiators

- **Voxeo VoiceCenter IVR** supports more standards-based integration...
 - W3C Voice Extensible Markup Language (VoiceXML)
 - W3C Speech Recognition Grammar Syntax (SRGS)
 - W3C Speech Synthesis Markup Language (SSML)
 - W3C Call Control Extensible Markup Language (CCXML)
 - W3C XML Path Language (XPath)
 - IETF Session Initiation Protocol (SIP)
 - IETF E.164 Numbers in DNS (ENUM)
 - IETF Media Reservation Control Protocol (MRCP)
 - IETF Voice Profile for Internet mail (VPIM)
 - IETF Zero Configuration Networking (Zeroconf)
 - IETF Authentication and Accounting (RADIUS)
 - IETF System Logging (Syslog)



Platform Differentiators

- **Voxeo VoiceCenter IVR** supports more enhanced features...
 - **Comprehensive call control for applications that go beyond IVR**
 - IP-ACD, IP-PBX, Caller ID Enhanced Services, Follow-me/Find-me applications
 - **CCXML Call conferencing for 2 to 200 participants**
 - Stand-alone conferencing, IVR integrated conferencing, call monitoring
 - **Statistical-percentage call recording**
 - Addressing FTC Telesales/3rd Party Verification, VUI Analysis, Quality Control
 - **Support for multiple voice browsers**
 - Nuance, VoiceGenie and OpenVXI VoiceXML, Microsoft SALT
 - **The most proven SIP / VOIP and CCXML platform**
 - Almost 3 years of 100% SIP/CCXML IVR - 350 million calls handled



Platform Architecture

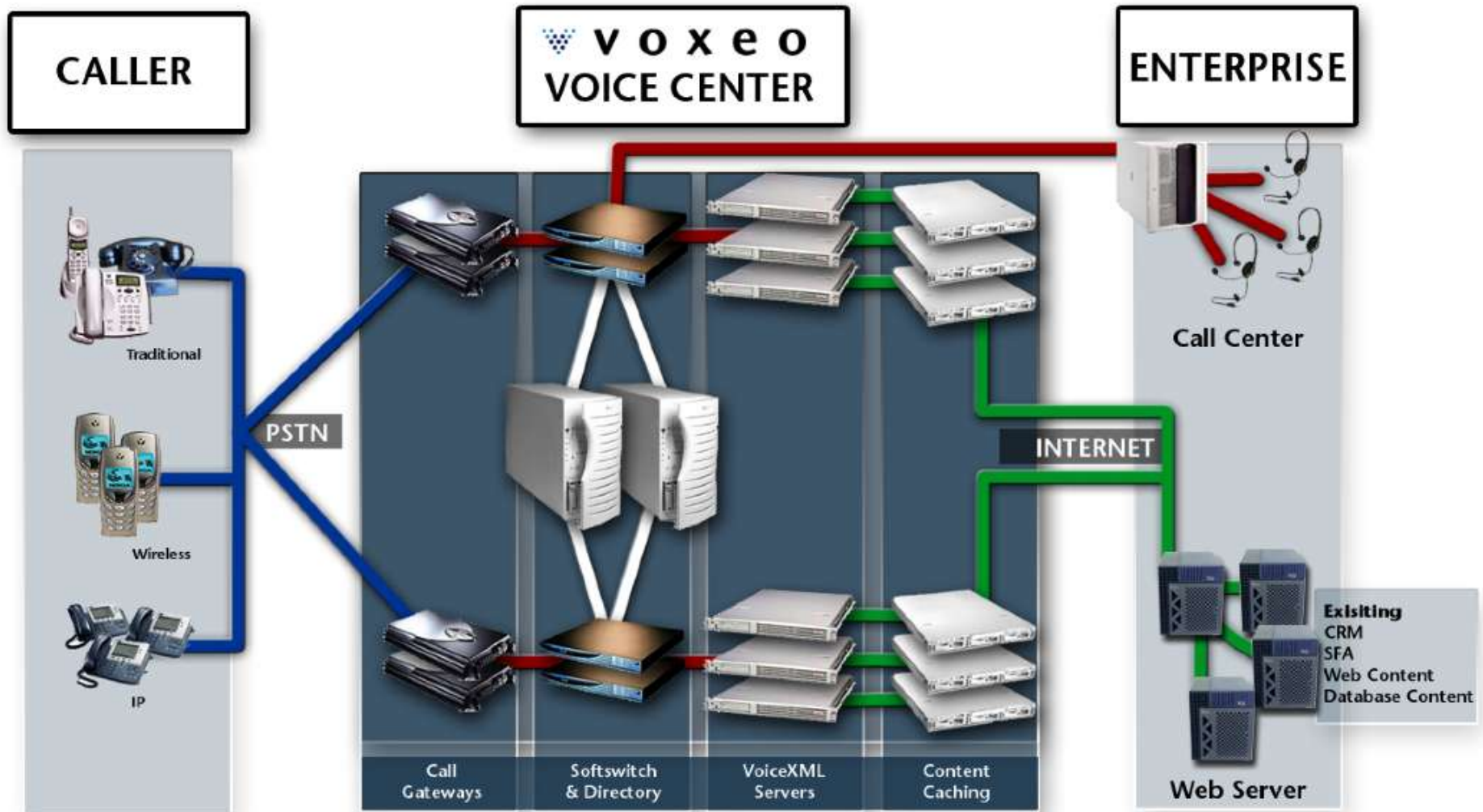



Platform Features

- **VoiceXML IVR**

- Audio play & record
- Voice recognition
- DTMF Input
- Text to Speech
- N-Best recognition
- Voice verification
- VoiceXML 2.0 & 2.1
- Multi-language support
- SIP/CCXML Integration
- Extremely scalable
- Motorola/Voxeo Browser

- **Call Control**

- Access to caller-id, called-id, ANI and DNIS
- Selective call answer
- Outbound call initiation
- Blind call transfer
- Call transfer with supervision
- PSTN Network transfer/ Take back & transfer

- **Call Conferencing**

- 2 to 200 line call conferencing
- Built in echo cancellation
- Built in noise suppression
- Dual band automatic gain control (agc)
- Listen-only participants
- Ability to add, remove and mute participants
- Completely CCXML controlled

- **CTI/Call Center Integration**

- Support for Cisco ICM / Geotel, Genesys, Nortel, Lucent, and more.
- Intelligent screen pop
- Directed transfer
- Asynchronous call transfer
- Modular architecture
- Completely CCXML controlled





Hosting Differentiators

- **Reliability**
 - Every port is deployed redundantly in Orlando and Atlanta
 - Seamless load balancing and failover between Orlando and Atlanta
 - Voxeo was the first IVR vendor to offer a 100% uptime guaranteed SLA

- **Flexibility**
 - Call termination: Multiple carriers, PSTN or VOIP
 - IVR Ports: Shared, dedicated, or on-demand burst capacity
 - Application servers: Voxeo provides co-location and managed server options

- **Enhanced features**
 - Voxeo VUI Analysis, Design, and Tuning
 - Voxeo Name & Address capture
 - Voxeo Evolution IVR Designer
 - Voxeo IVR Load Testing
 - Voxeo IVR Monitoring



Hosting Features

- Tiered architecture: Voice Gateway tier, Softswitch & directory tier, VoiceXML server tier, Content caching tier
- Tiers interconnected with dual gigabit ethernet LAN
- Complete intra-Voice Center redundancy
- No single point of failure
- Carrier-class Cisco Voice Gateways
- Carrier-class Voxeo CCXML Softswitch
- Carrier-class BIND ENUM DNS directory servers
- Motorola/Voxeo VoiceXML servers
- Voxeo VoiceXML monitoring agents
- Nuance distributed voice recognition
- Completely redundant high performance caching
- Connected to PSTN and Internet with redundant fiber
- Always on UPS with generator backup
- Redundant cooling and dehumidifiers
- Water-free FE-227 fire suppression system
- Multiple geographically distributed, redundant voice centers
- Low level performance metrics, monitoring, and alarming
- Application level call simulation testing and alarming

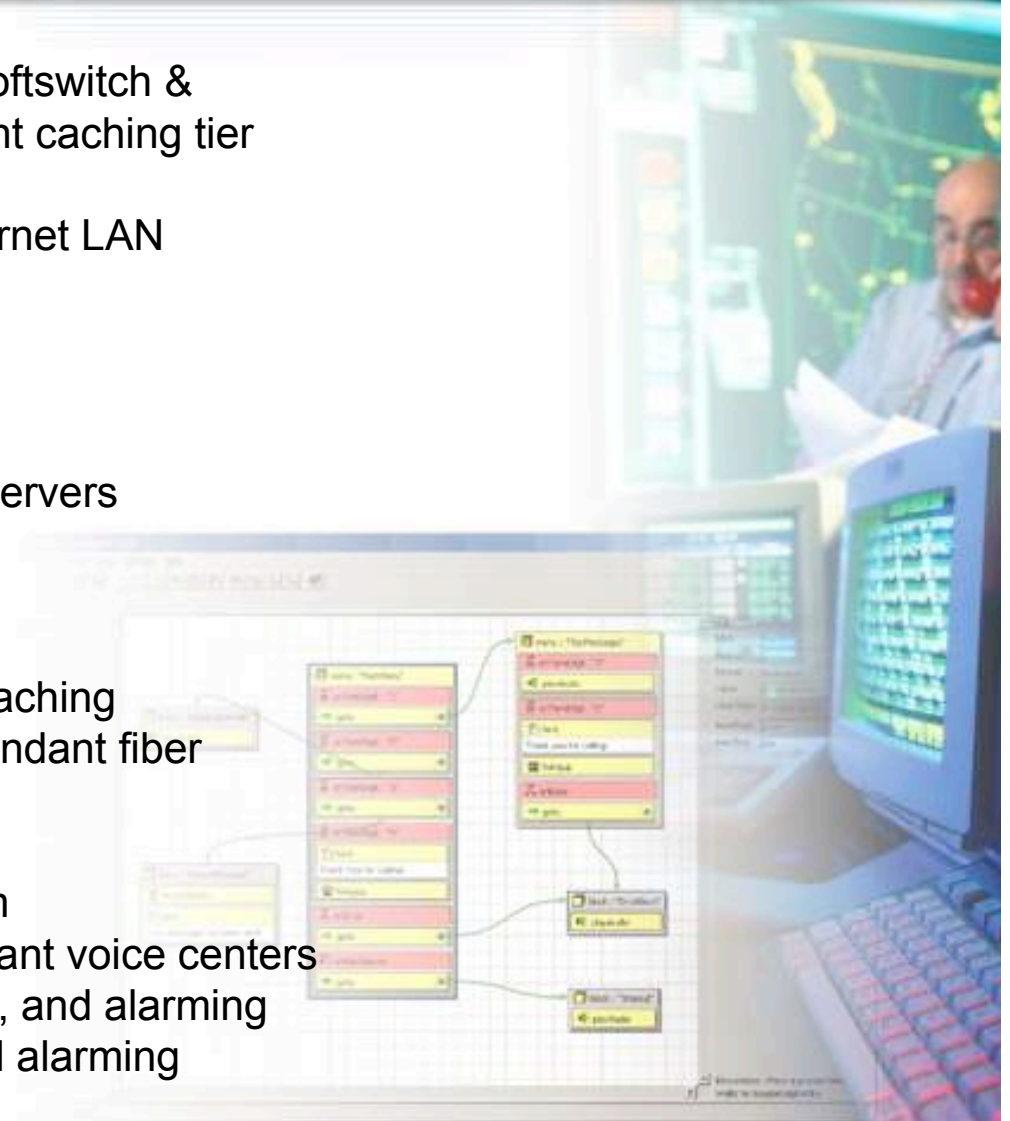



Developer Solutions

- Voxeo Evolution Community

- Free Developer web site
- Free VoiceXML, CCXML, and CallXML IVR Hosting
- Free tutorials, reference guide & forum-based support
- Actively improved and supported

- Voxeo Evolution Professional

- Paid developer program
- Includes Evolution Designer
- Email and Instant message technical support
- Access to other enhanced services



Support & Services

-Voxeo Extreme Support: Top-notch free technical support

- 24 x 7 via telephone, email and instant-message
- Automatic web & email-based trouble ticket system
- Public support forums - provide a growing public knowledgebase
- All agents are skilled VoiceXML/CCXML development professionals
- Voxeo's agents were among the first developers in the world to take VoiceXML Forum Developer Certification tests

- Voxeo Extreme Services: Valuable Professional Services

- Load testing, monitoring, managed VUI, prompts, etc...



Applications

- Voxeo VoiceWorks Program

- Packaged IVR platform/hosting + IVR application solutions
- Applications created by Voxeo customers & industry partners
- Best-of-breed applications sold, supported, and managed by Voxeo

- Voxeo Voice Works Applications

- Call routing, customer support, survey, notification and custom apps for:

- | | | |
|--------------|----------------------|---------------------------|
| - Healthcare | - Call Centers | - Travel & Transportation |
| - Utilities | - Retail sales | - Integrators & VAR's |
| - Financial | - General enterprise | - Government agencies |



Summary

- **Profitable.**
- **Rapid growth** from new customers, new minutes, and new services.
- **Customers:** Fortune 50 to 50 of the most innovative companies in IVR.
- **Business advantages:** Self-sufficient; evolved, proven platform and process.
- **Technical advantages:** Call control, redundancy, flexibility, standards.
- **Innovative developer programs** that are actively supported and improved.
- **The best support in the industry**, period.
- **Best-of-breed packaged IVR solutions** from Voxeo, customers and partners.